

TECHNOLOGY

HOLYKELL®

HR1200

LEVEL

• **DATASHEET** •

- 1. Pressure Measurement** **2. Level Measurement** **3. Temperature Measurement**
4. Flow Measurement **5. Display & Control Instruments**
6. Wireless Monitoring System **7. Velocity Measurement**

HR1200

60GHz Millimeter Wave Radar Level Sensor

Applications

- Water treatment
- Water tank measurement
- Chemical industry
- Petrochemical process storage tanks
- Pharmaceutical industry
- Food and beverage manufacturing
- Refining process vessels
- Sewage treatment
- Hydroelectric power generation & dams
- Process control



Features

- Small size, easy to install with the assistance of the built-in bubble spirit level
- New development with unique beautiful appearance and advanced technology
- No-contact measurement adopted, without cleaning difficulty and maintenance
- Receiving little impact by corrosion, foam, vapor, temperature and pressure changes
- Standard RS485 MODBUS protocol supported
- Connection of host computer setting software, tank side meter and others
- Wide power supply range with minimized power consumption

Profile

HR1200 60GHz millimeter wave radar level meter is a new level sensor developed by Holykell. It adopts a non-contact measurement, which is clean and reduces maintenance possibility. The completely new design makes it a different and delicate appearance. A bubble spirit level is installed on the top surface, which greatly helps in the device installation.

The product features high accuracy, up to $\pm 2\text{mm}$ and can detect small targets, which achieves preciser positioning. Besides, its stability is high thanks to its strong anti-interference ability.

HR1200 is designed to mainly measure liquids, and has a wide range of applications.

Specifications

Parameter	HR1200
Frequency	1~10Hz
Measuring range	0.2-12m for water 0.2-8m for diesel 0.2-6m for gasoline
Measurement accuracy	±2mm
FOV angle	8°
Lens antenna size	15mm
Center frequency	60GHz
Communication rate	Default 115200bit/s, 9600/19200/38400 free change
Scanning frequency	1-10Hz
Communication Mode	RS485 MODBUS RTU
Power Supply	12Vdc recommended (9-24Vdc available)
Operational temperature	-40~85°C
Power consumption	Minimum power:0.2W(8V*16.847mA) Maximum power:0.45W(12*36.168mA)
Product Size	Ø73*82mm
Protection class	IP68
Weight	440.5g(not including the connection wire)

■ Dimensions and Drawing

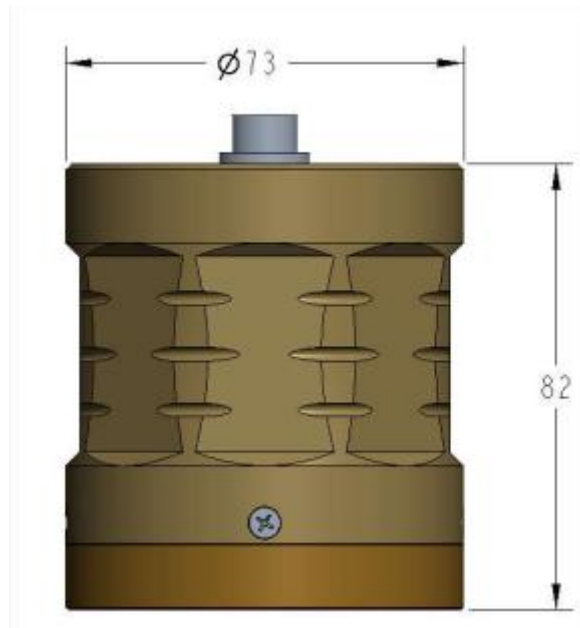

Unit: mm

■ Wiring

Pin No.	Definition	Wire Color
1	VCC	Red
2	GND	Black
3	RS-A	Yellow
4	RS-B	Green

How to Order

1. Range Selection Table:

01	0~1	02	0~2	03	0~3	04	0~4	05	0~6	06	0~8	07	0~10	08	0~12
X	By customized														

Kindly according to your application select suitable range code , Example: code 03 =3 .
 Unit of measure select on the Part Number Selection Table . Example: Code H=m H₂O, that's 3m H₂O

2. Part Number Selection Table:

1200 Selection Type	07	H	E11	S5	CW	2	001
Range	Range reference to range selection table code						
Level Units	H=m H ₂ O (Min: 0.2 mH ₂ O; Max:12 mH ₂ O) M=m Fuel (Min: 0.2 mH ₂ O; Max:12 mH ₂ O)						
Signal Output	E11=RS485(MODBUS) X= By Customized						
Power Supply	S5=12Vdc	S41=9-24Vdc					
Measuring Medium	CW=Water D=Diesel G=Gasoline X=Others Liquid and Density By Customized						
Accuracy	2=±2mm						
Cable length	001= Cable 1m	002= Cable 2m	X= By Customized				